

## SPRINKLER HEAD

### Upright, Pendent & Recessed Pendent Sprinklers

**MODEL: SD1010, SD1015, SD1030, SD1032**

#### DESCRIPTION

The SHIELD Sprinklers, SD1010, SD1015, SD1030, SD1032 (Glass Bulb Type), Standard Orifice, Upright, Pendent and Recessed Pendent type, design incorporates state-of-the-art, heat responsive, frangible glass bulb design (standard or quick response) for prompt, precise operation.

The die cast frame is more streamlined and attractive than traditional sand cast frames. It is cast with a hex-shaped wrench boss to allow easy tightening from many angles, reducing assembly effort. This sprinkler is available in various temperature ratings and finishes to meet many design requirements. The recessed pendent should be utilized with a recessed escutcheon which provides up 3/4" of adjustments. All Sprinklers are manufactured using the time proven Belleville seal used exclusively by all major manufactures to ensure long life and safe operation.

#### SPRINKLER OPERATION

The operating mechanism is a frangible glass bulb which contains a heat responsive liquid. During a fire, the ambient temperature rises causing the liquid in the bulb to expand. When the ambient temperature reaches the rated temperature of the sprinkler, the bulb shatters. As a result, the waterway is cleared of all sealing parts and water is discharged towards the deflector. The deflector is designed to distribute the water in a pattern that is most effective in controlling the fire.

#### MAXIMUM COVERAGE

Standard spray coverage is up to: Light Hazard = 225 square feet(20.9 sq.m); Ordinary Hazard = 130 square feet(12.1 sq.m) per NFPA 13.

#### RATINGS

Sprinkler Temperature Classification	Normal Sprinkler Temperature Rating	N.F.P.A Maximum Ambient (Ceiling) Temp.(Allowed)	Glass Bulb Color
Ordinary**	155°F/57°C	100°F/38°C	Orange
Ordinary	155°F/68°C	100°F/38°C	Red
Intermediate	175°F/79°C	150°F/65°C	Yellow
Intermediate	200°F/93°C	150°F/65°C	Green
High*	286°F/141°C	225°F/107°C	Blue
Extra High*	360°F/182°C	300°F/149°C	Mauve
Open*	Open	-	No Bulb

\* Non-Approved  
\*\*UL Listed only.



#### TECHNICAL SPECIFICATION

Sprinkler Identification Number	Standard SD1015, SD1010 (bulb 5mm), Quick Response SD1030, SD1032 (bulb 3mm)
Style	Upright Sprinkler SD1015, SD1032, Pendent & Recessed Pendent SD1010, SD1030
K Factor	5.6gpm/psi <sup>1/2</sup> . (80lpm/bar <sup>1/2</sup> )
Response Time Index (RTI)	Standard 50 Quick Response 30
Nominal Thread Size	1/2"NPT(15mm)
Orifice Size	13mm
Max. Working Pressure	175PSI(1200kPa)
Factory Hydrostatic Test	100%@500PSI(3450 kPa)
Min. Operation Pressure	7 PSI(48 kPa)

## PART LIST

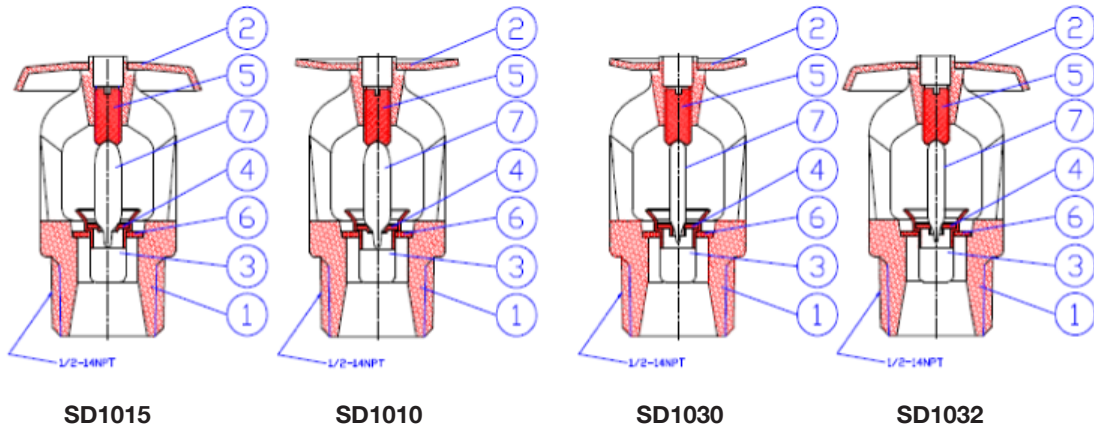

1. Frame      2. Deflector      3. Cap      4. Cap Seat      5. Load Screw      6. Seal      7. Bulb

## DISCHARGE CURVE

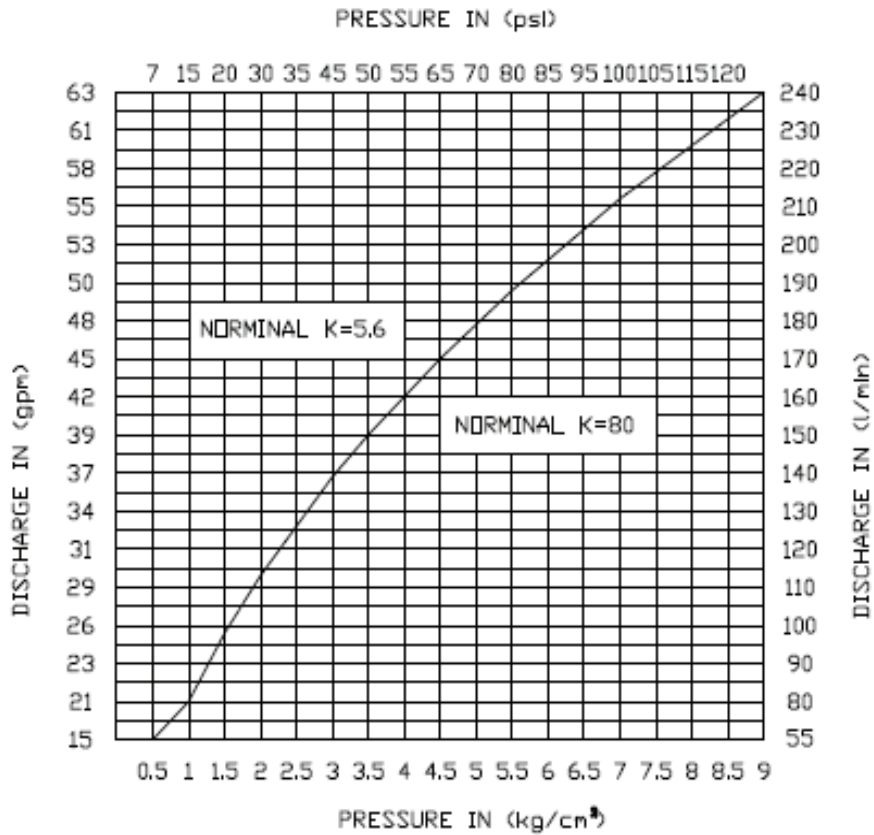

## WARNINGS

The SHIELD sprinklers must be installed and maintained in compliance with this document. Depressurize and drain the piping system before attempting to install, remove, or adjust any Sprinklers. Failure to do so may impair the performance of these sprinklers. The owner is responsible for maintaining the fire protection system and devices in operation.

## WRENCH DESCRIPTION

The Sprinkler Wrench is a tool specifically designed for installing SHIELD Sprinklers. These special wrenches must be used to provide the proper leverage when tightening the sprinkler and to minimize slippage during installation. Any other wrench may damage the sprinkler.



Sprinkler Wrench

## INSTALLATION

All SHIELD Sprinklers must be installed according to NFPA 13 Standards. Deviations from these requirements and standards or any alteration to the sprinkler itself will void any warranty made by manufacturer. In addition, installation must also meet local government provisions, codes and standards as applicable.

The system piping must be properly sized to insure the minimum required flow rate at the sprinkler. Check for the proper model, style, orifice size and temperature rating prior to installation. Install sprinklers after the piping is in place to avoid mechanical damage, replace any damaged units. Wet pipe systems must be protected from freezing.

Upon completion of the installation, the system must be tested per recognized standards. In the event of a thread task, remove the unit, apply new pipe joint compound or tape, and reinstall.

## ADDITIONAL

Recessed Sprinkler - To install the escutcheon plate, align with it and push or thread over the sprinkler body into the upper support piece, until the outer edge of the escutcheon meets the mounting surface.

## INSTALLATION SEQUENCE

Step 1 - The unit must be installed in the upright position for the Upright Sprinklers, and in the Pendent position for the Pendent Sprinkler, Pendent Recessed Sprinkler.

Step 2 - Use only a non-hardening pipe joint compound or tape seal. Apply only to the male threads.

Step 3 - Hand tighten the sprinkler into fitting.

Step 4 - For Upright and Pendent Sprinklers, use a standard wrench. Tighten the unit into the fitting. A lead-tight joint requires only 7 to 14ft.lbs (9.5 to 19.0Nm) of torque. A tangential force of 14 to 28 ft.lbs (62.3 to 124.5N) delivered through a 6”(150mm) handle will deliver adequate torque. Once torque level reach over 21ft.lbs (28.6Nm) it may distort the orifice seal, resulting in leakage. For exposed piping systems, the sprinkler should be oriented so the frame arms are parallel with the branch line pipe.

## CAUTION

Do not over-tighten or under-tighten the sprinkler to compensate for inaccurate escutcheon plate adjustment.

Protection clips are used to protect its bulb. Please have clip on at all times during transportation.

## MAINTENANCE

Sprinklers must never be altered after manufacture. Any alteration such as painting and coating will directly harm the sprinkler and cause malfunctions.

Sprinkler in contact with corrosive products should be replaced if they cannot be cleaned completely.

Visual inspections are recommended after installation. After installation, a close-up inspection annually will suffice.

Inspection and maintenance of fire protection system is the responsibility of the owner. It is recommended that automatic sprinkler system be inspected and tested according to local and/or national regulations.

## DISTRIBUTION PATTERNS

K5.6 PENDENT SPRINKLER  
DISTRIBUTION PATTERNS - TRAJECTORY

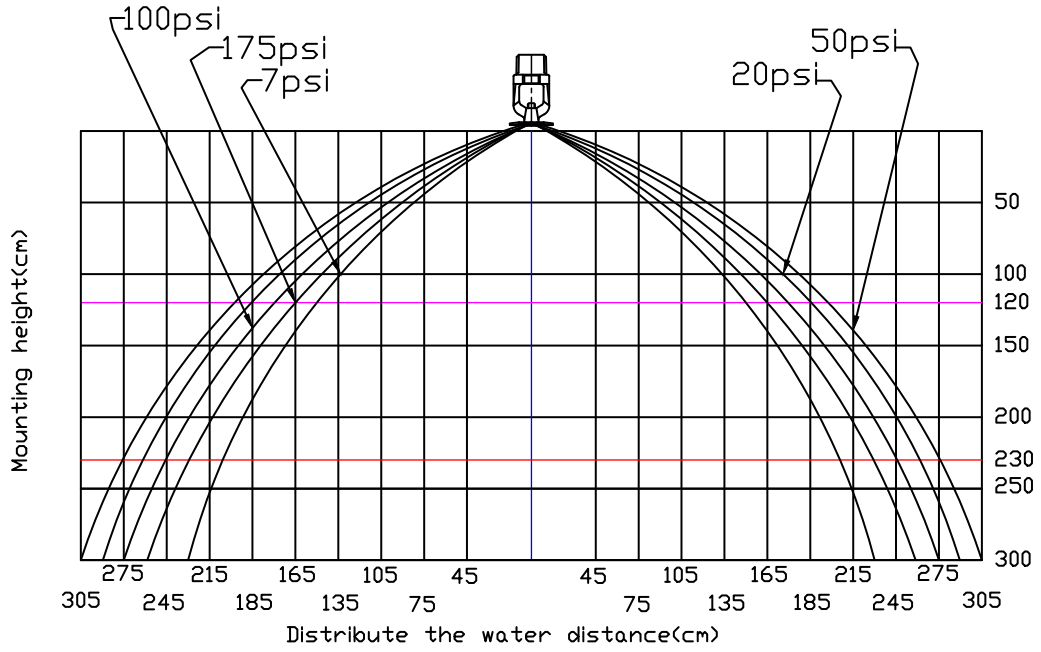

K5.6 UPRIGHT SPRINKLER  
DISTRIBUTION PATTERNS - TRAJECTORY

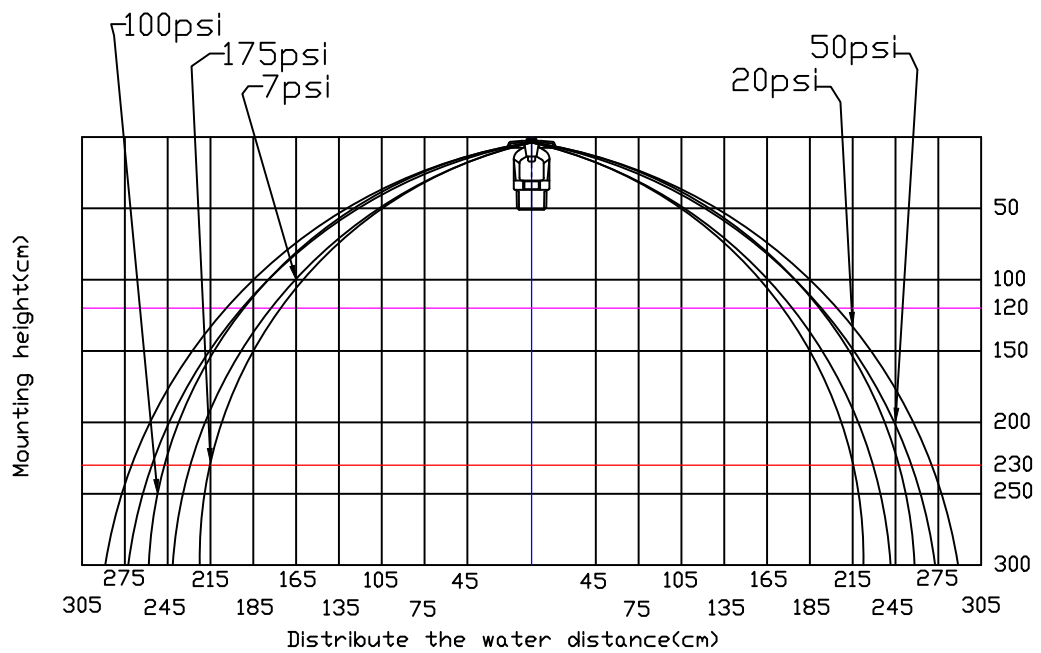

## DIMENSIONS

UPRIGHT SPRINKLER

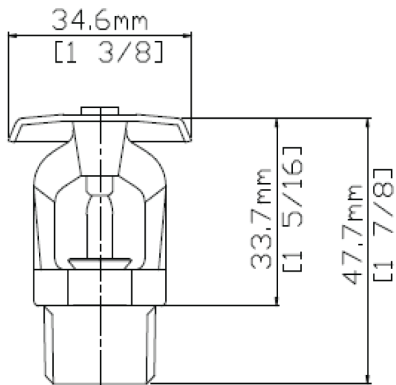

PENDENT SPRINKLER

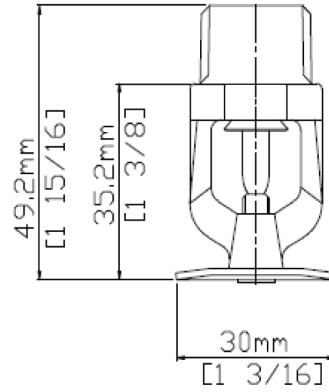

RECESSED PENDENT SPRINKLER

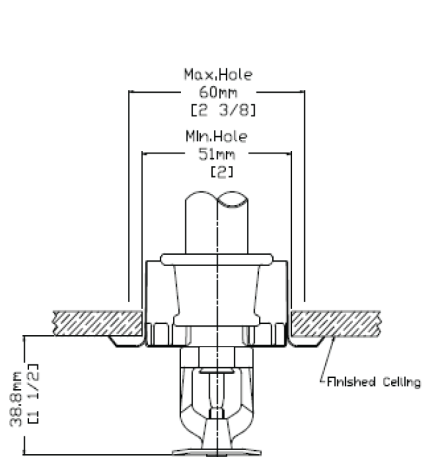

Maximum Extension

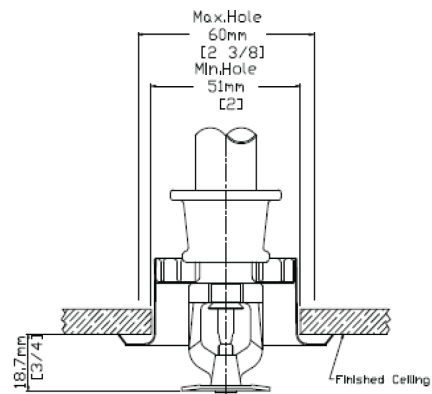

Maximum Recess